

ISSUE	DETAILS	DATE
A	TO BE APPROVED FOR MANUFACTURE	

FITTING POSITIONS SHOWN ARE STANDARD. PLEASE INDICATE WITH DIMENSIONS IF REQUIRED IN A DIFFERENT LOCATION.  
TANK SHOWN IS SUITABLE FOR SCREW TYPE SENDER (WITH PICKUP / RETURN PIPES SEPARATE FROM THE SENDER UNIT).

SCREW TYPE SENDER UNIT MOUNTING PLATE  
Sender Plate is supplied blank and will need to be drilled and tapped by customer unless sender is supplied for fitment

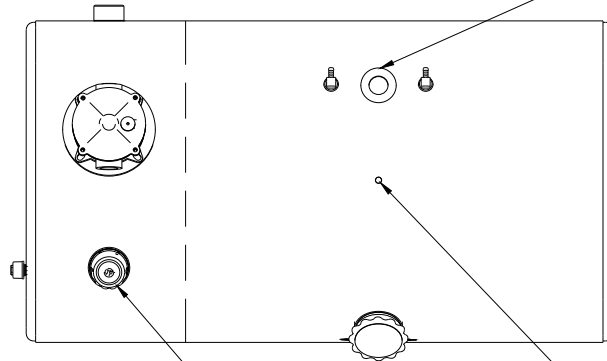

CHROME FILLER/BREATHER

BRASS FUEL TANK BREATHER

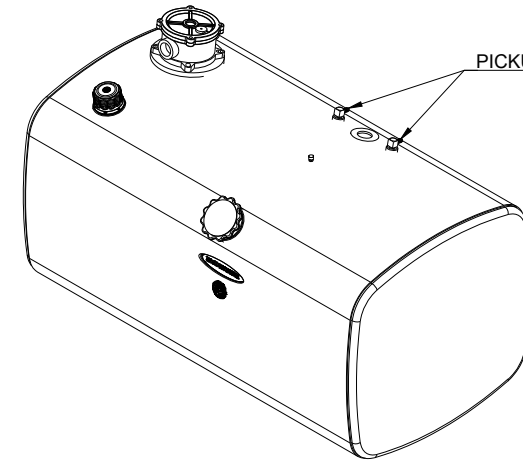

PICKUP/RETURN PIPES

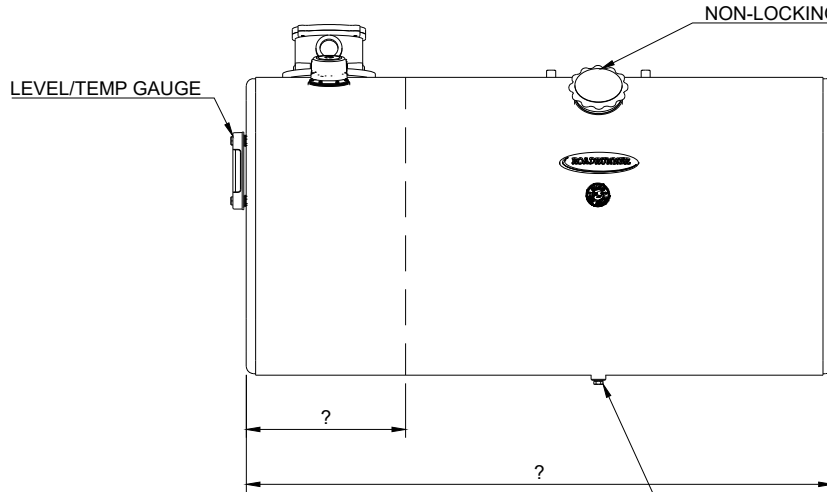

NON-LOCKING ROADRUNNER FUEL CAP

LEVEL/TEMP GAUGE

3/8" BSP DRAIN AND BUNG

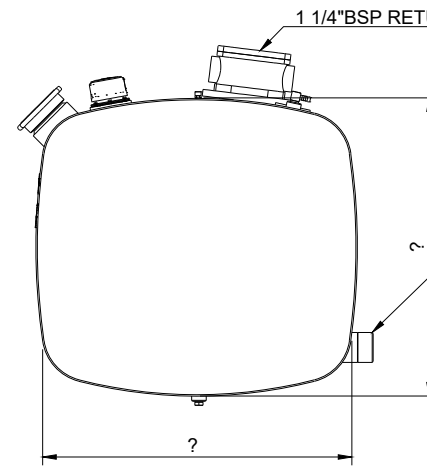

1 1/4" BSP RETURN FILTER

1 1/4" BSP SUCTION PORT

TANK ORIENTATION	
630H x 680D	
680H x 630D	
650H x 700D	
700H x 650D	

THIS DRAWING AND/OR ELECTRONIC MEDIA CONTAINING THIS DRAWING REMAIN THE PROPERTY OF ROADRUNNER MANUFACTURING LTD. IT MAY NOT BE COPIED OR USED IN ANY UNORTHERRISED MANNER

**ROADRUNNER**  
ROADRUNNER MANUFACTURING (NZ) LIMITED



CLIENT:			SHEET:
TITLE: Oval Sq Combo Tank - Screw Type Sender	DATE:	SCALE: 1:16	1/1
DRAWN BY: Steve Tunncliffe	PRODUCT CODE:	JOB NUMBER	ISSUE: